



Assembly Instructions









AUGUST LOTZ
CRAFTING INNOVATION
Since 1897

Frame Models
Artisan (1620) & Phoenix (1743)



Tel: (800) 826-7326
Fax: (715) 597-6625
www.augustlotz.com
alotz@augustlotz.com

51149 Whitetail Rd.
Osseo, WI 54758

Hardware List

- | | |
|--------------------|---|
| (4) Long JC Bolts |  |
| (4) Short JC Bolts |  |
| (8) Barrel Nuts |  |
| (1) 4mm Hex Wrench |  |
| (4) Nylon Rollers |  |
| (6) Clevis Pins |  |
| (6) Washers |  |
| (6) Hair Pins |  |
| (2) Plastic Stops |  |
| (4) Screws |  |

Frame Parts

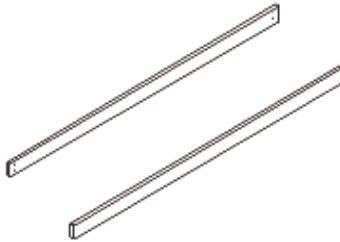
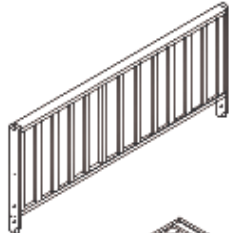
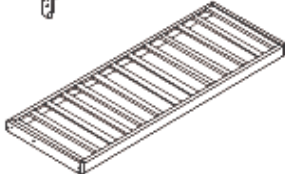
- | | |
|--|-----------------|
|  | (1) Right Arm |
|  | (1) Left Arm |
|  | (2) Cross Rails |
|  | (1) Back Rest |
|  | (1) Seat |

TOOLS NEEDED: Slotted Screwdriver & Phillips Screwdriver

- 1) Before beginning the actual assembly of your frame, make sure that all of the parts described on the front page are included in your frame's box.
- 2) Locate the backrest (the backrest has a rounded top rail). Locate the seat. With the slats in seat and backrest facing downward, slide the back (holes are nearer the back) of seat between legs of backrest (Figure 1).

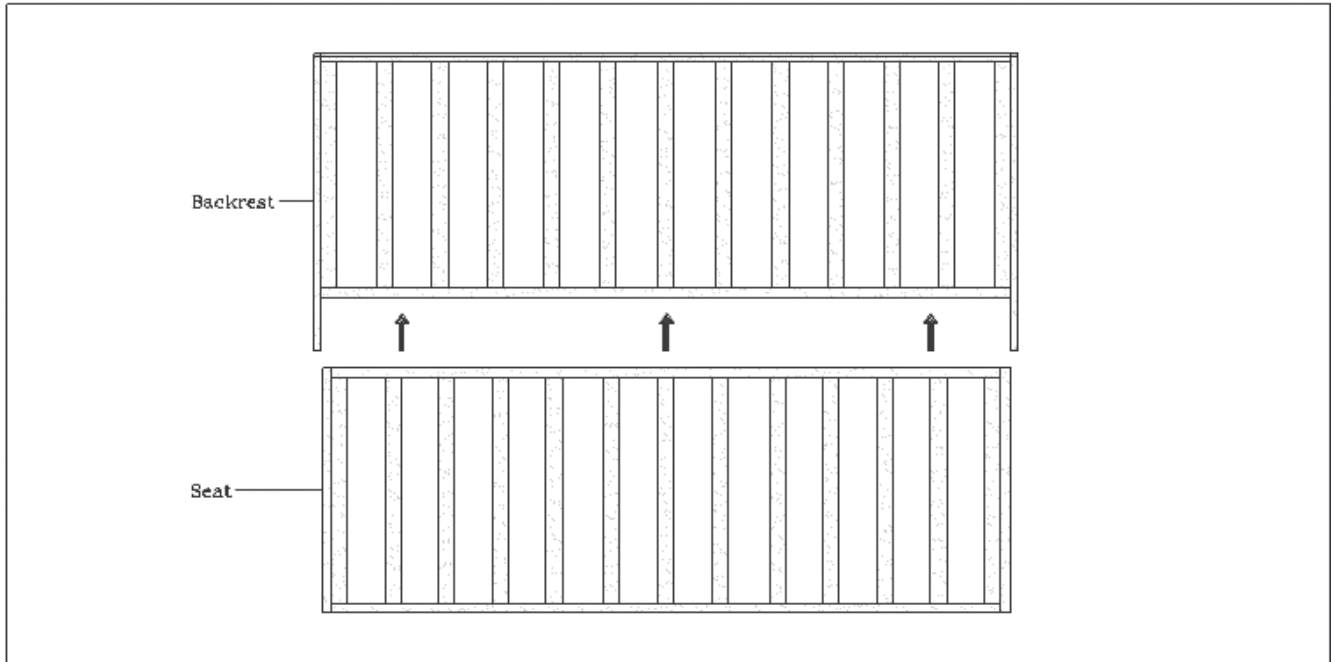

Figure 1

- 3) Line up the hole in backrest with the end hole in seat. Push a clevis pin through hole until it bottoms out in backrest. Place a flat washer over the clevis pin and insert a hair pin into clevis pin. Repeat for opposite side (Figure 2).

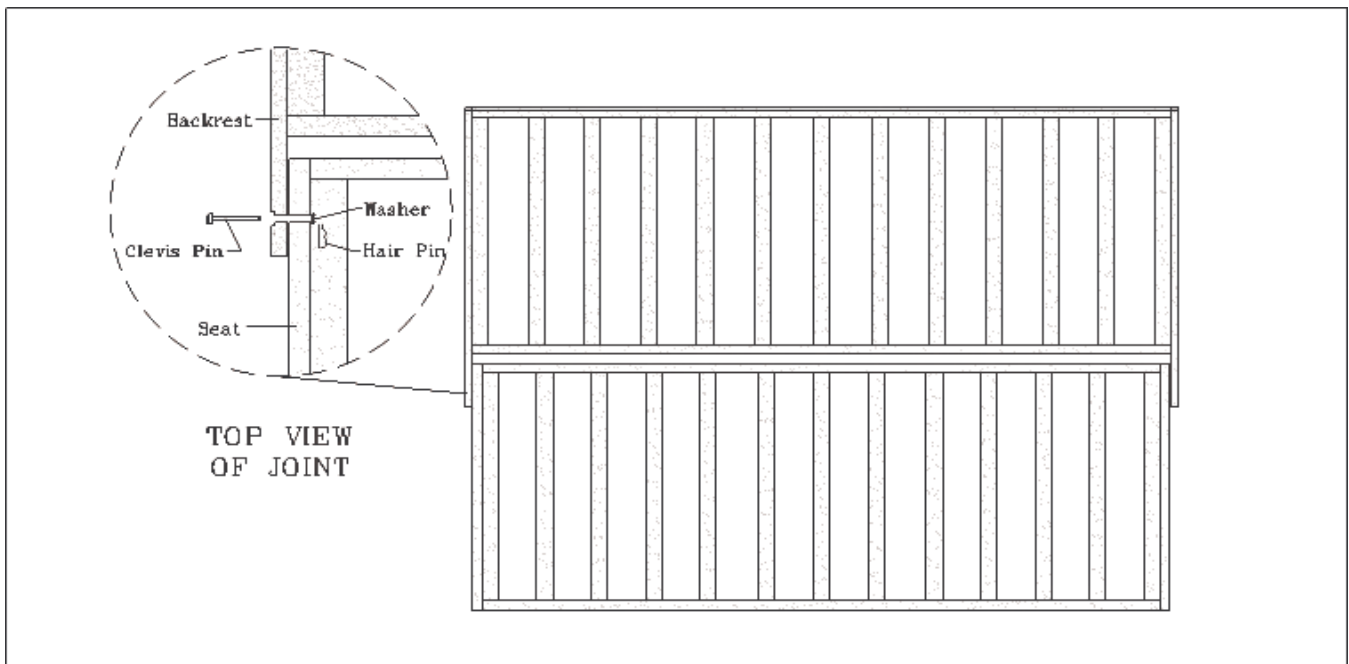

Figure 2

- 4) Locate backrest. Place clevis pin through narrow end of a nylon roller and then through one of the two remaining holes in the side of backrest. Place a flat washer on the end of the clevis pin. Insert hair pin through clevis pin hole. Repeat this step for remaining rollers (Figure 3).

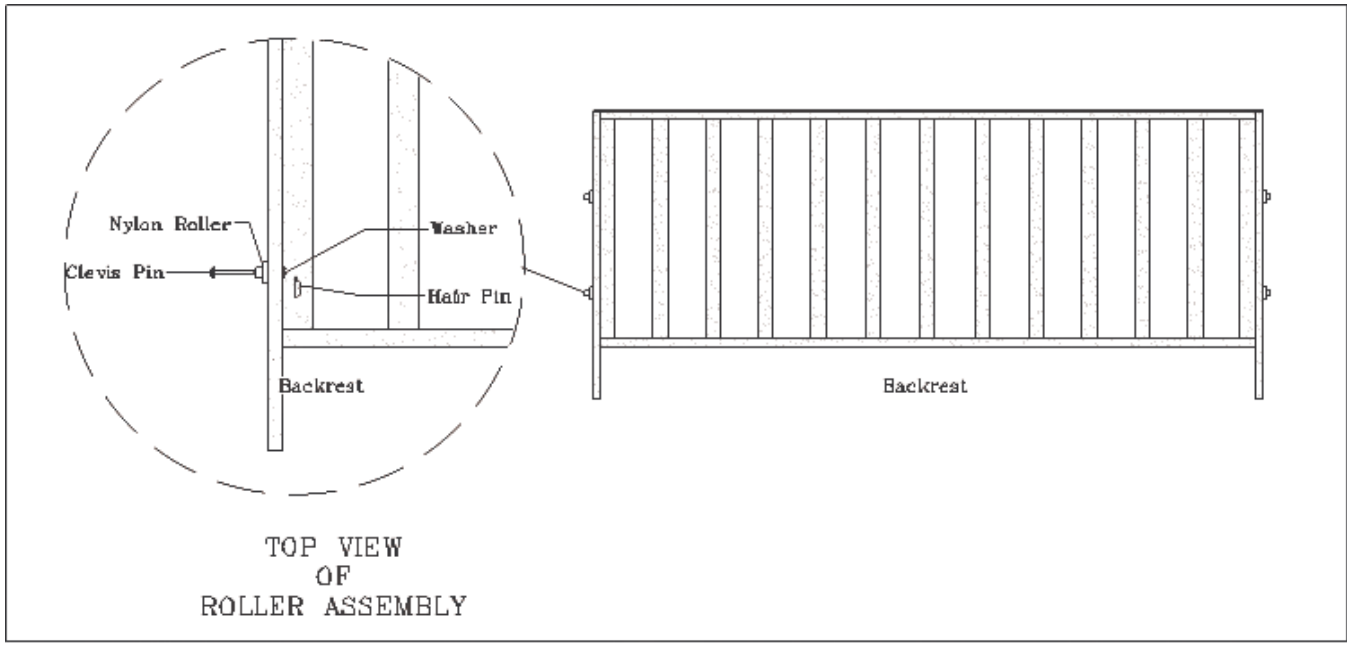

Figure 3

- 5) Locate plastic stops. Locate four small holes on bottom of seat (2 at each end). Insert stops into frame (Figure 4). Use Phillips screwdriver to set screws. Do not use a screw gun and be careful not to over tighten screws.

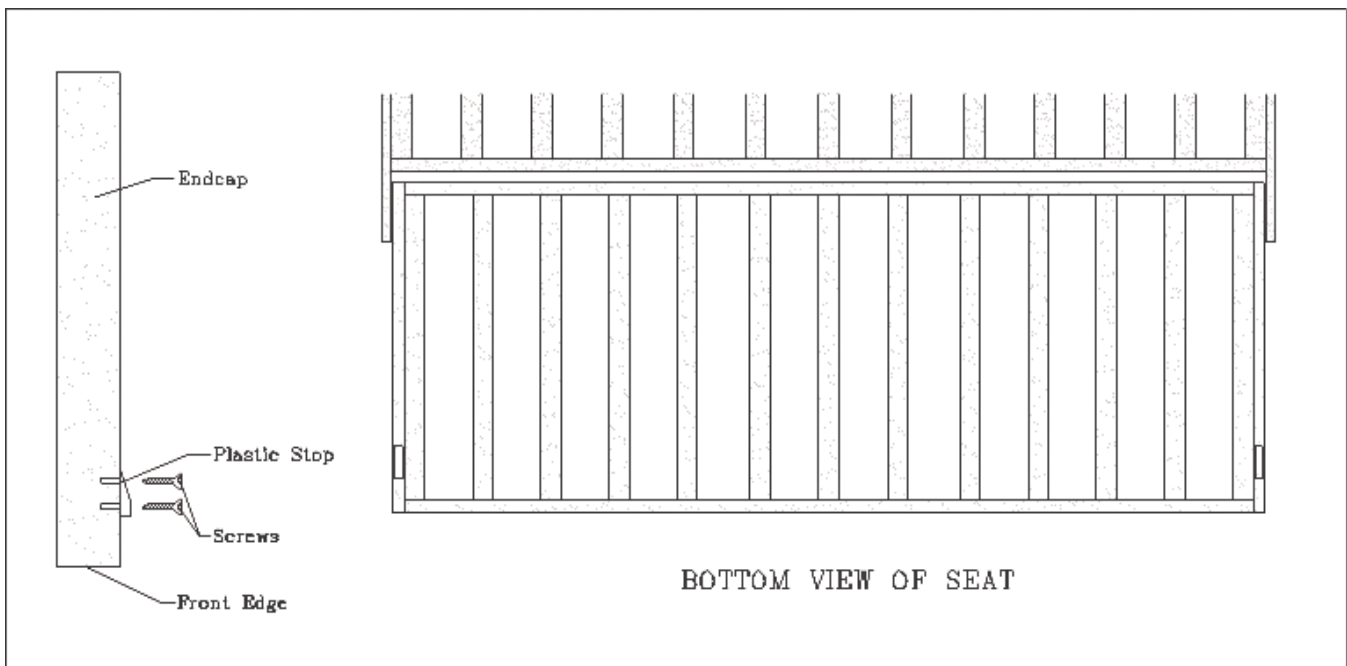

Figure 4

- 6) Locate arm assemblies and one of the cross rails. Place a barrel nut in each hole in side of cross rail. Make sure that the threaded holes in barrel nuts line up with holes in ends of rail and that the slotted end of barrel nut is exposed (Figure 5). Also, if assembling frame model 1620, make sure that the rail marked “Front” is facing with the metal guards up and the front sticker to the inside of the frame.

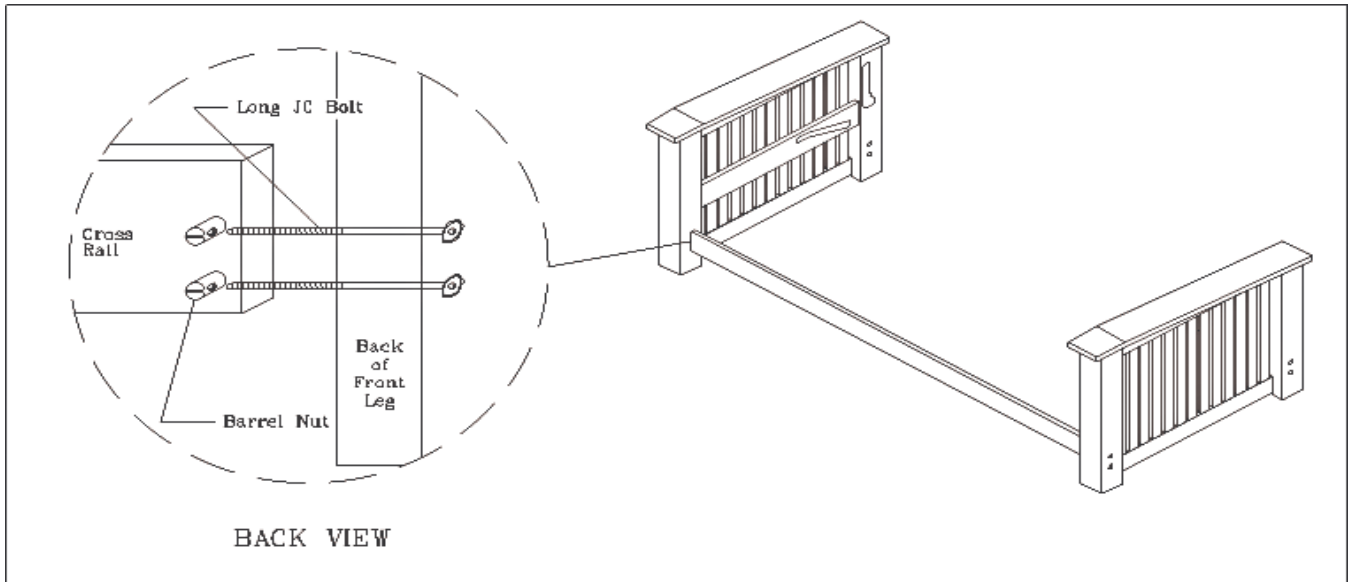

Figure 5

- 7) Place long JC bolt through top hole in outside of arm assembly's front leg and start it into a barrel nut in one of the cross rails. Be sure slotted end of barrel nuts are toward inside of frame. **DO NOT TIGHTEN!** If bolt won't start, use slotted screwdriver to position barrel nut. Leave about 1/4" of play. Place long JC bolt through bottom hole and start it, also leaving 1/4" of play. Repeat procedure for other arm. When all 4 bolts are set, gently pull back legs apart just past point of armrest being parallel (Figure 5).
- 8) Turn backrest/seat assembly over so slats are facing upward. With backrest still lying flat on the floor, pick end of seat up until it rests on backrest (Figure 6).

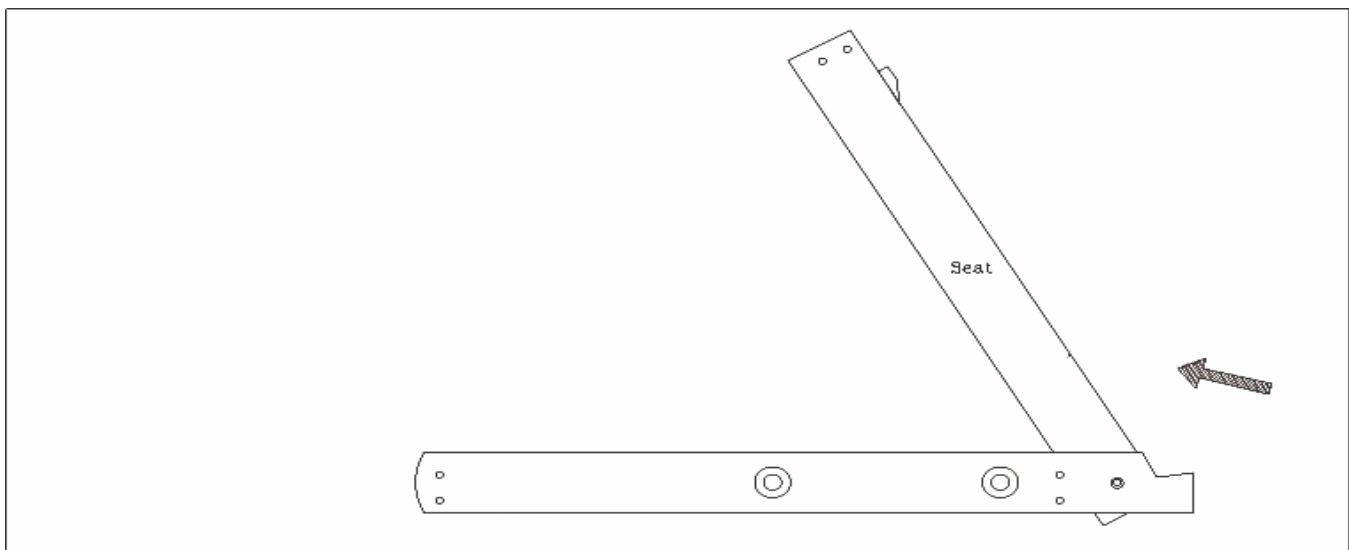

Figure 6

- 9) With the help of a friend, pick up backrest/seat assembly and place into arm/cross rail assembly completed in step #7. The two nylon rollers on backrest will slide into groove on inside of each arm (Figure 7). Pull backs of arms together to hold seat in place.

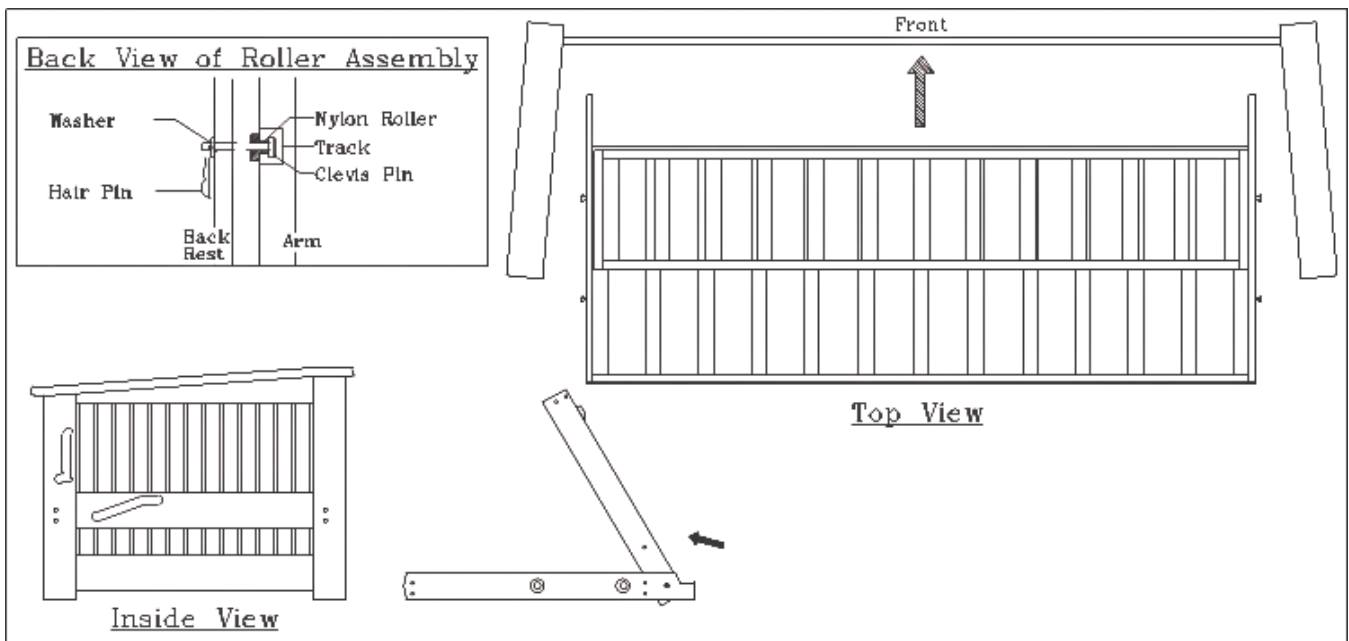

Figure 7

- 10) Tighten long JC bolts in front leg. Fasten remaining cross rail to back legs of arm assembly as shown in step #7, but using short JC bolts instead. Tighten securely.

Please Review Conversion Instructions on Next Page

Conversion Instructions

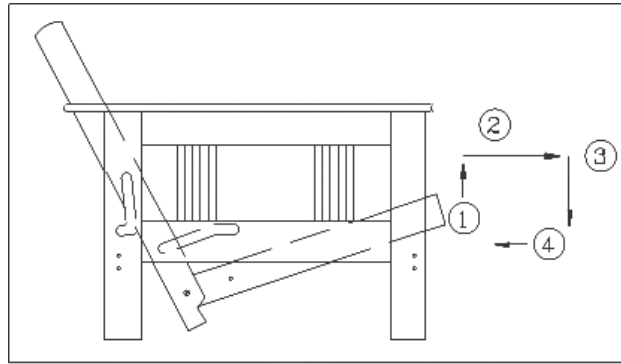

Figure 1

To Convert Into A Bed

- 1) While standing in front of sofa-bed convertible, grasp front seat rail. Lift seat high enough to clear plastic stops.
- 2) Slowly pull seat assembly toward you until back leg's roller rests at bottom of its groove.
- 3) Set the seat section down (Figure 1).
- 4) Push the seat section backwards about an inch so that it locks into bed position (Figure 1).

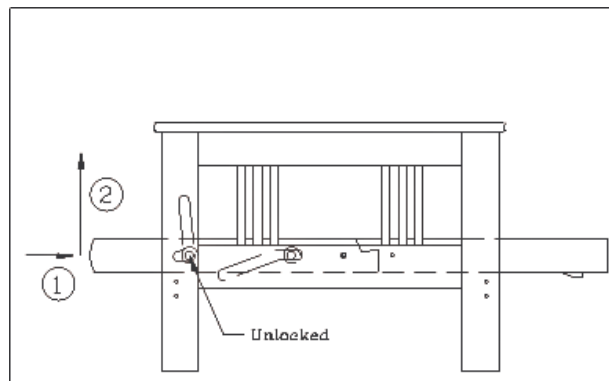

Figure 3

To Convert Back Into A Sofa

- 1) While standing in back of sofa-bed convertible, push the backrest forward (about an inch), until it's out of the lock position (Figure 3). This is very important! You could possibly damage the frame if you try to convert it into upright position when it is locked. Manufacture is not responsible for damage caused by converting while locked.
- 2) Lift the backrest upward until the plastic stops on the bottom of the seat are pulled within the framework to the inside of the front cross rail (Figure 1).

Note: To avoid structural damage, we recommend that you do not lift it by the armrest. (Instead lift by the center rail of the arm assembly.)