



AUGUST LOTZ
CRAFTING INNOVATION
Since 1897



Assembly Instructions

Michigan Avenue (#4200A)

Tel: (800) 826-7326
Fax: (715) 597-6625
www.augustlotz.com
alotz@augustlotz.com

51149 Whitetail Rd.
Osseo, WI 54758

Hardware List

- | | |
|--|---|
| (8) JC Bolts |  |
| (8) Barrel Nuts |  |
| (1) 4mm Hex Wrench |  |
| (4) Nylon Rollers |  |
| (8) Clevis Pins |  |
| (8) Washers |  |
| (8) Hair Pins |  |
| (2) Plastic Stops |  |
| (4) Screws |  |
| (2) Lotz Easy Glider
Wooden Kickers |  |

Frame Parts

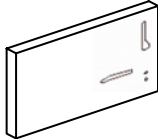
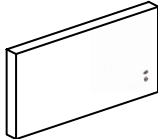
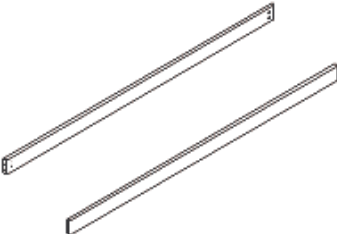
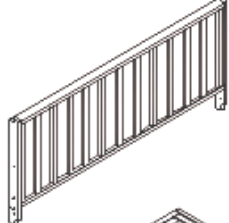
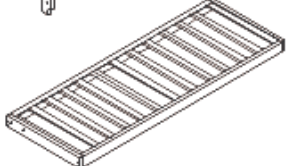
- | | |
|--|-----------------|
|  | (1) Right Arm |
|  | (1) Left Arm |
|  | (2) Cross Rails |
|  | (1) Back Rest |
|  | (1) Seat |

TOOLS NEEDED: Slotted Screwdriver & Phillips Screwdriver

- 1) Before beginning the actual assembly of your frame, make sure that all of the parts described on the front page are included in your frame's box.
- 2) Locate the backrest (the backrest has a rounded top rail). Locate the seat. With the slats in seat and backrest facing downward, slide the back (holes are nearer the back) of seat between legs of backrest (Figure 1).

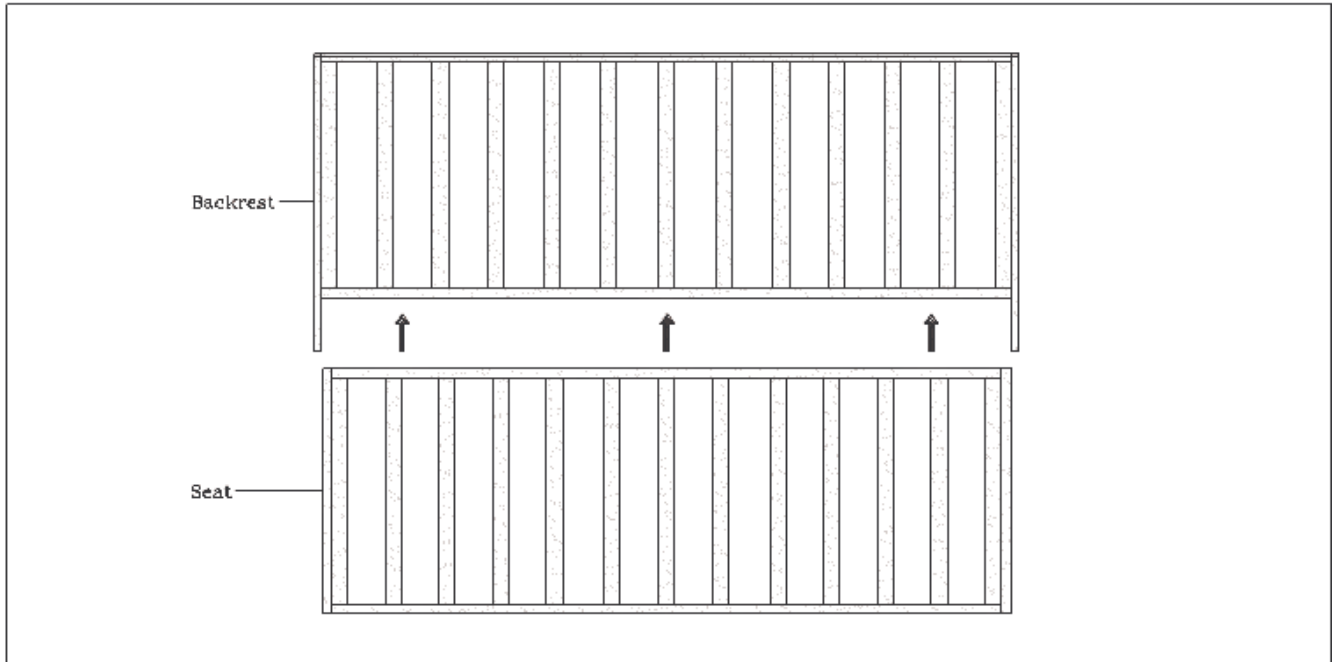

Figure 1

- 3) Line up the hole in backrest with the end hole in seat. Push a clevis pin through hole until it bottoms out in backrest. Place a flat washer over the clevis pin and insert a hair pin into clevis pin. Repeat for opposite side (Figure 2).

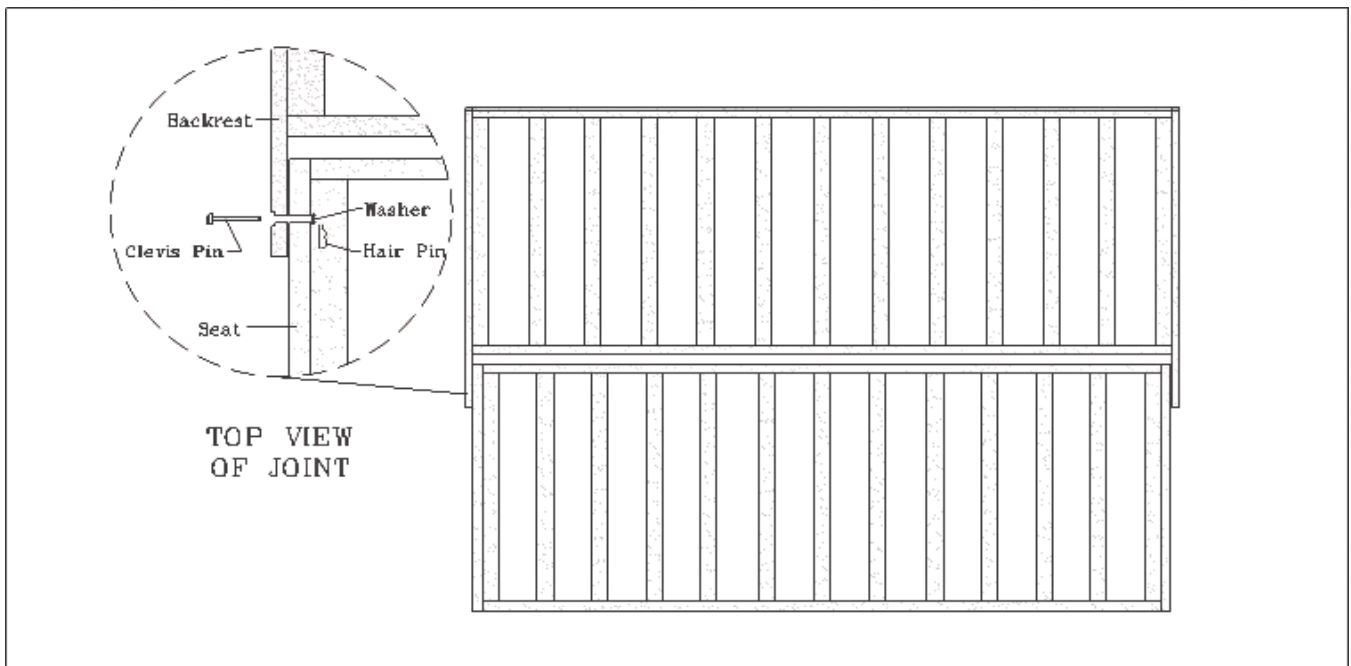

Figure 2

- 4) Locate backrest. Place clevis pin through narrow end of a nylon roller and then through one of the two remaining holes in the side of backrest. Place a flat washer on the end of the clevis pin. Insert hair pin through clevis pin hole. Repeat this step for remaining rollers (Figure 3).

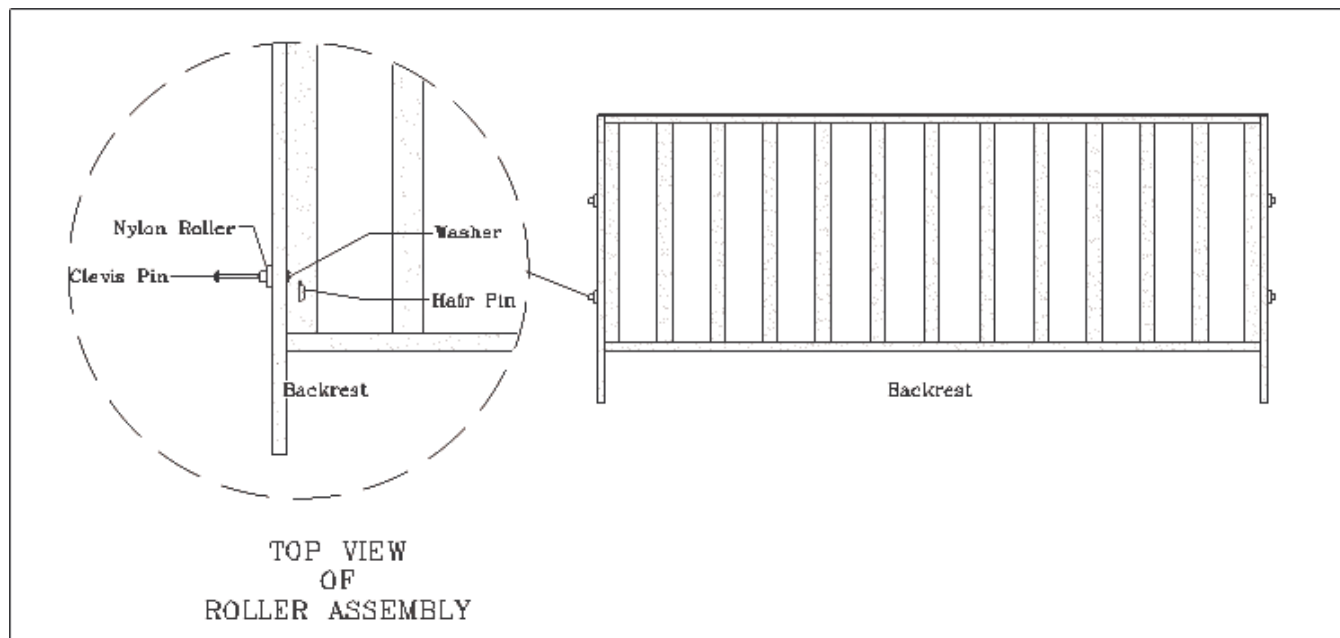

Figure 3

- 5) Locate kickers. Insert a clevis pin through side of kicker. Push clevis pin through remaining hole inside of seat. Secure clevis pin with flat washer and hair pin. Repeat for opposite side (Figure 4).

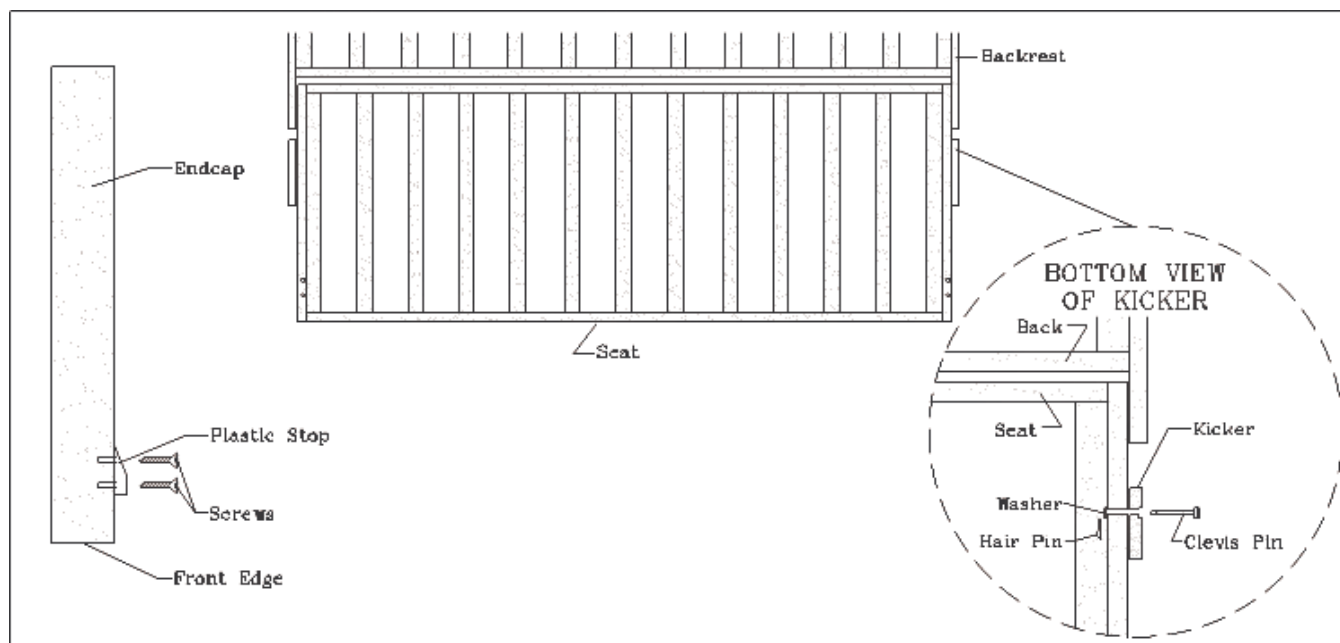

Figure 4

- 6) Locate plastic stops. Locate four small holes on bottom of seat (2 at each end). Insert stops into frame (Figure 4). Use Phillips screwdriver to set screws. Do not use a screw gun and be careful not to over tighten screws.

- 6) Locate arm assemblies and one of the cross rails. Place a barrel nut in each hole in side of cross rail. Make sure that the threaded holes in barrel nuts line up with holes in ends of rail and that the slotted end of barrel nut is exposed (Figure 5). Also, make sure that the rail marked “Front” is facing with the metal guards up and the front sticker to the inside of the frame.

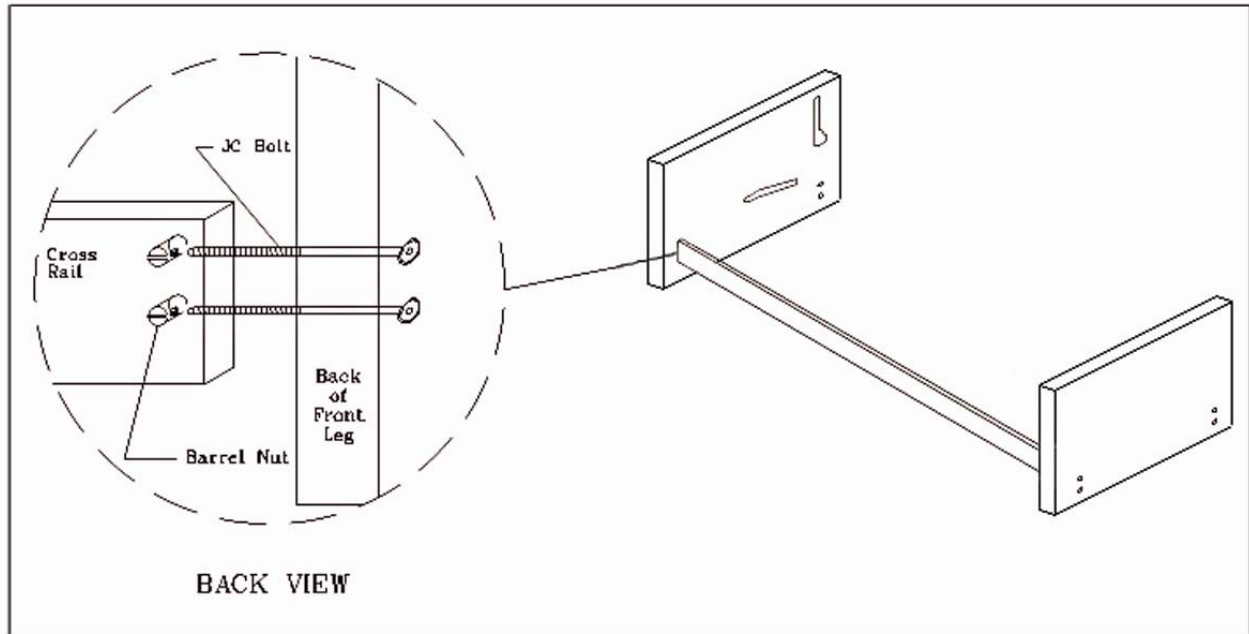

Figure 5

- 8) Place JC bolt through top hole in outside of arm assembly's front leg and start it into a barrel nut in one of the cross rails. Be sure slotted end of barrel nuts are toward inside of frame. **DO NOT TIGHTEN!** If bolt won't start, use slotted screwdriver to position barrel nut. Leave about 1/4" of play. Place JC bolt through bottom hole and start it, also leaving 1/4" of play. Repeat procedure for other arm. When all four bolts are set, gently pull back legs apart just past point of armrest being parallel (Figure 5).

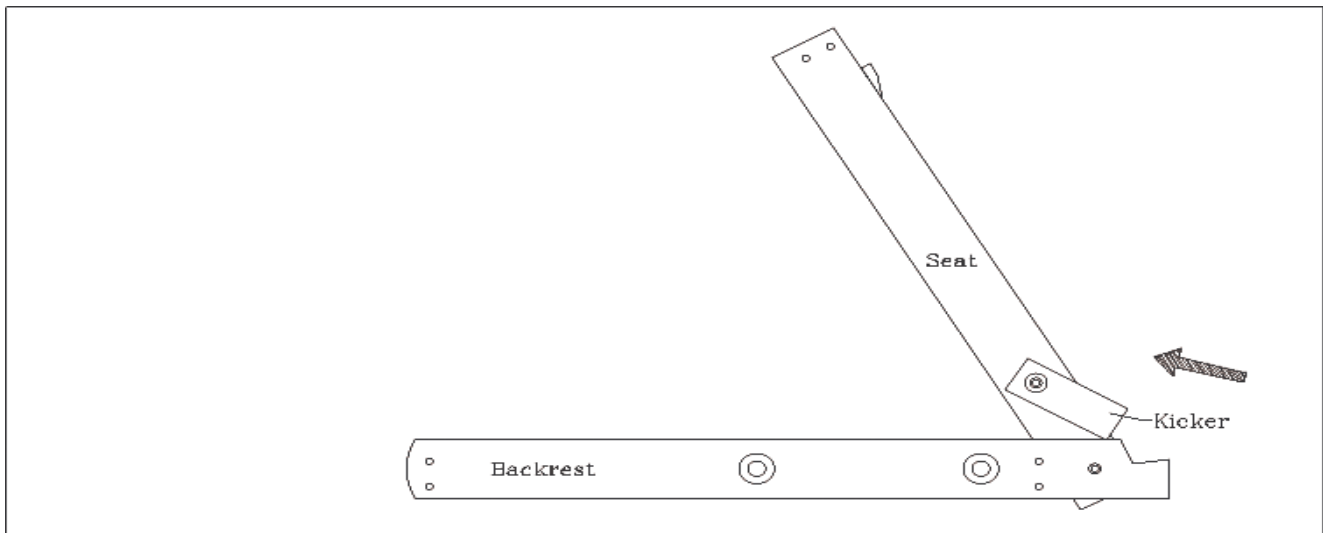

Figure 6

- 10) With the help of a friend, pick up backrest/seat assembly and place into arm/cross rail assembly completed in step #8. The two nylon rollers on backrest will slide into groove on inside of each arm (Figure 7). Pull backs of arms together to hold seat in place.

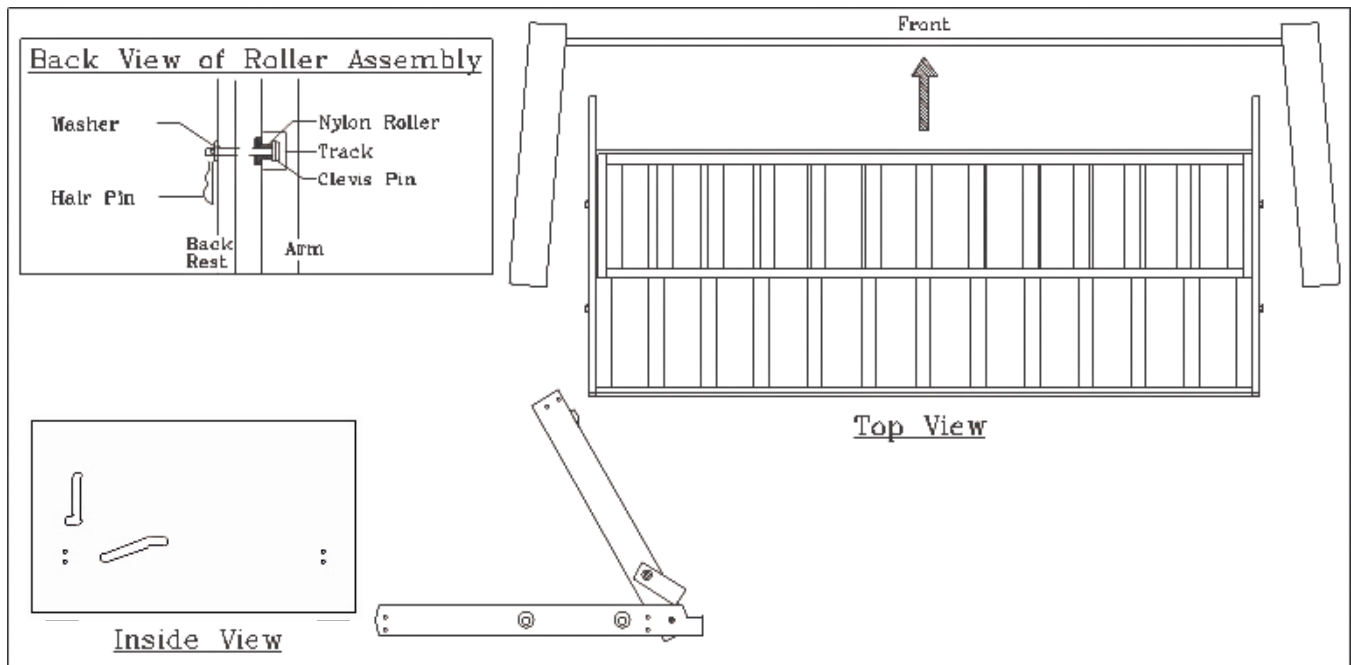

Figure 7

- 11) Tighten JC bolts in front leg. Fasten remaining cross rail to back legs of arm assembly as shown in Figure 5. Tighten securely.

To Convert Into A Sofa

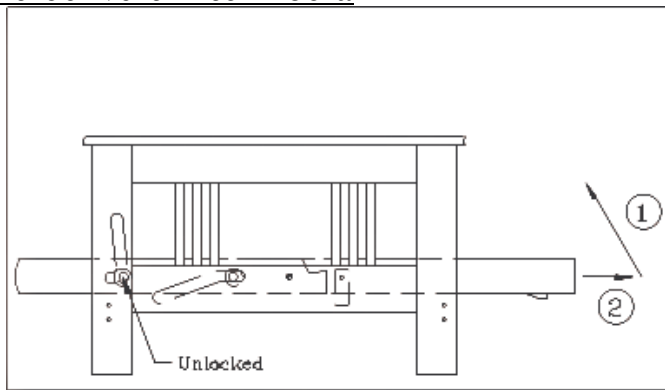

Figure 3

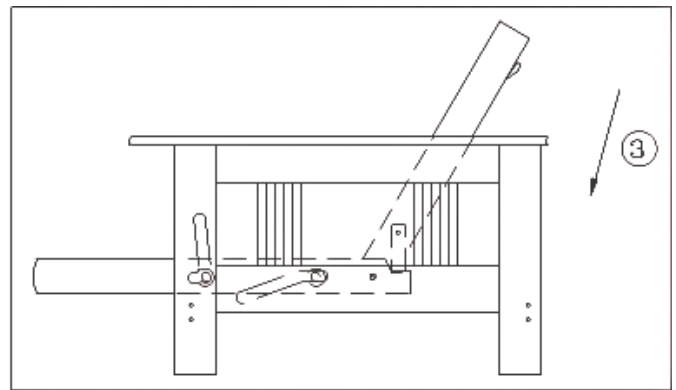

Figure 4

- 1) While standing in front of the sofa-bed convertible, lift the seat up and toward the backrest until the wooden kickers slide into notches in the backrest's legs (Figure 3).
- 2) Pull the seat forward about an inch to release it from the locked position (Figure 3).
- 3) Push down on front end of seat. This will raise backrest into its sofa position (Figure 4).
- 4) When the seat comes to rest on the front cross rail, push the seat backwards until the plastic stops fall behind the rail.

NOTE: If you have any difficulties, check that the backrest is out of the locked position and that the kickers are in proper position.

To Convert Into A Bed

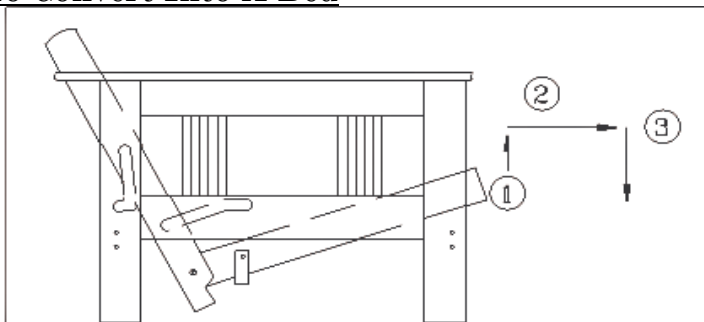

Figure 1

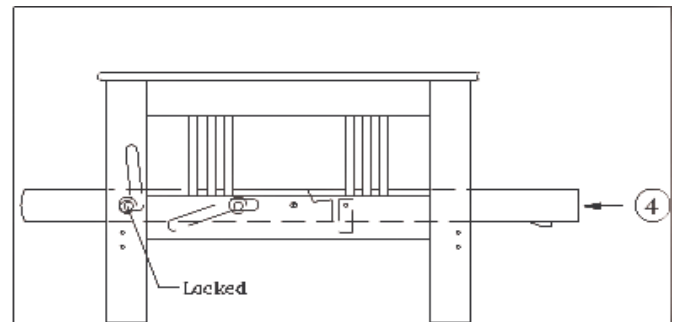

Figure 2

- 1) While standing in front of the sofa-bed convertible, grasp the front seat rail. Lift seat up about an inch, high enough to clear the plastic stops (Figure 1)
- 2) Slowly pull the seat assembly toward you until the roller in the back leg rests at the bottom of its groove (Figure 1).
- 3) Set the seat section down (Figure 1).
- 4) Push seat section back (about an inch) so that it locks into the bed position (Figure 2)

WARRANTY NOTICE

FAILURE TO FOLLOW FRONT LOAD CONVERSION
INSTRUCTIONS WILL CANCEL WARRANTY